

FOR CHEMICAL INVENTORY MANAGEMENT

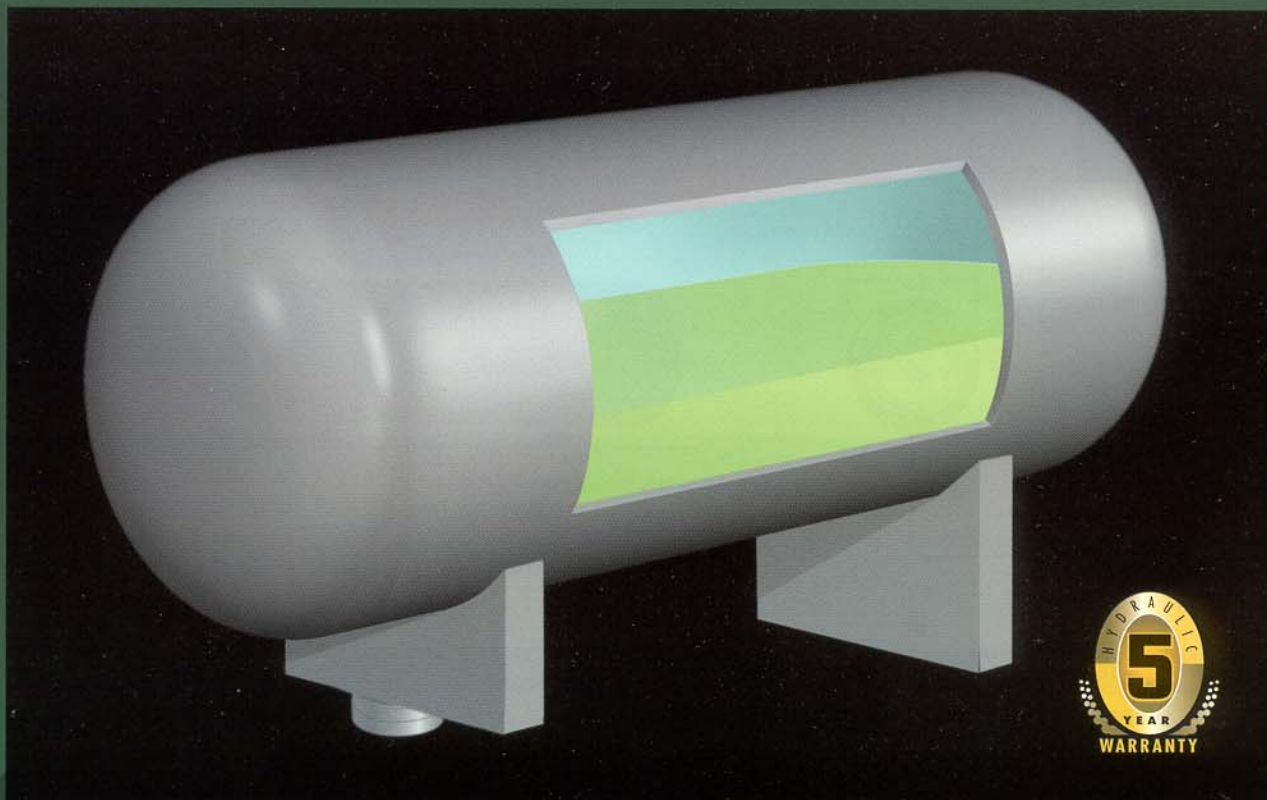

APPLICATIONS INCLUDE:

CHLORINE,
SULFUR DIOXIDE
AND AMMONIA
TANKS



HYDRAULIC SYSTEM
REQUIRES NO POWER.
IT IS VIRTUALLY
MAINTENANCE FREE
AND IS IMMUNE TO
POWER FAILURE,
LIGHTNING STRIKES
AND RFI/EFI.

FORCE FLOW'S CHLOR-SCALE STATIONARY TANK WEIGHING SYSTEM IS DESIGNED TO TURN ANY SADDLE SUPPORTED VESSEL INTO AN INVENTORY MONITORING SYSTEM. THE CHLOR-SCALE IS AN AFFORDABLE, NON-INTRUSIVE, HIGHLY RELIABLE METHOD OF MEASURING LEVEL. WEIGHT (OR MASS) IS AN INHERENTLY ACCURATE MEANS OF MEASURING VESSEL CONTENTS BECAUSE IT IS INDEPENDENT OF VESSEL SHAPE, TEMPERATURE, AND SPECIFIC GRAVITY OF THE CONTENTS.

THE HYDRAULIC LOAD CELL SYSTEM REQUIRES NO POWER AND IS IMMUNE TO POWER FAILURE, LIGHTNING STRIKES, RFI, ETC. THIS MAKES IT IDEAL FOR OUTDOOR INSTALLATIONS OR REMOTE LOCATIONS WHERE POWER IS UNAVAILABLE OR UNRELIABLE. OVER 25 YEARS OF EXPERIENCE MEANS YEARS OF RELIABLE AND DEPENDABLE SERVICE.

FORCE FLOW
EQUIPMENT

OVER 25 YEARS OF EXPERIENCE

CHLOR-SCALE® HYDRAULIC STATIONARY TANK WEIGHING SYSTEM

LOAD CELL SYSTEMS COME COMPLETE WITH DIAL, LOAD CELL AND 20 FEET OF HOSE WITH QUICK DISCONNECT AT DIAL. SPECIFY SPECIAL HOSE LENGTHS UP TO 30 FEET. FOR LENGTHS OVER 30 FEET, OTHER CAPACITIES, OR RECORDERS, CONTROLLERS AND ALARMS, PLEASE CONSULT FACTORY. METRIC DIALS AVAILABLE AT NO EXTRA CHARGE.

TO DETERMINE THE CAPACITY OF THE CHLOR-SCALE TO BE USED, YOU MUST DETERMINE THE GROSS WEIGHT OF THE SYSTEM. THE GROSS WEIGHT IS THE SUM OF THE NET WEIGHT OF THE PRODUCT, THE TARE WEIGHT OF THE VESSEL, AND ANY OTHER APPARATUS THAT WILL BE SUPPORTED ON THE CHLOR-SCALE.

SPECIFYING GUIDELINES: A) FOR MAXIMUM ACCURACY, SIZE SCALE CAPACITY TO MATCH GROSS WEIGHT (NET CHEMICAL WEIGHT PLUS TANK TARE WEIGHT). B) SUPPLY CONNECTIONS MUST BE FLEXIBLE AND CONNECTED AT PIVOT END OF VESSEL. C) SPECIFY TANK TARE WEIGHT IN THE SCALE SPECIFICATION.

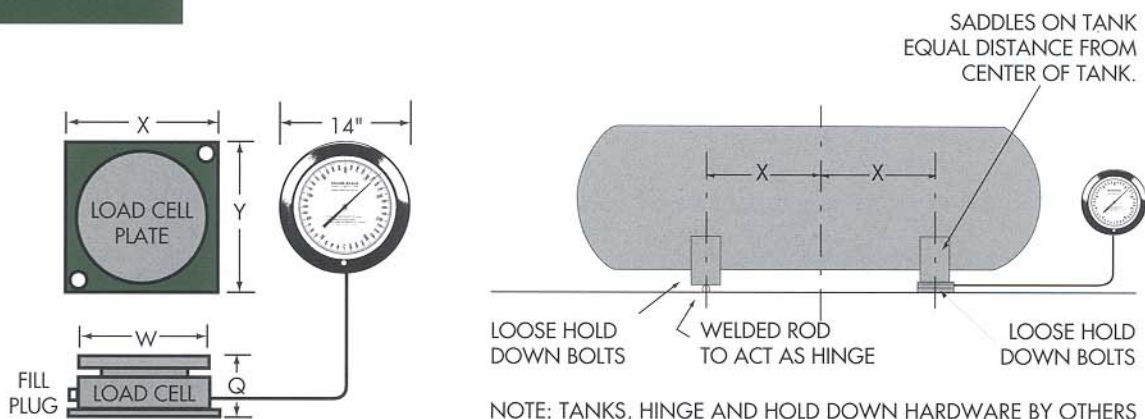

NOTE: TANKS, HINGE AND HOLD DOWN HARDWARE BY OTHERS

MODEL	CAPACITY	"X"	"Y"	"W"	"Q"	SHIPPING WEIGHT
12D50S	5,000 LBS	7" (178)	7" (178)	61/2" (165)	2-3/4" (70)	35 LBS
12D100S	10,000 LBS	7" (178)	7" (178)	61/2" (165)	2-3/4" (70)	35 LBS
12D150S	15,000 LBS	8 1/2" (216)	8 1/2" (216)	71/2" (190)	2-7/8" (75)	50 LBS
12D200S	20,000 LBS	13" (330)	13" (330)	13" (330)	31/2" (90)	130 LBS
12D300S	30,000 LBS	13" (330)	13" (330)	13" (330)	31/2" (90)	130 LBS
12D400S	40,000 LBS	13" (330)	13" (330)	13" (330)	31/2" (90)	130 LBS
12D500S	50,000 LBS	13" (330)	13" (330)	13" (330)	31/2" (90)	130 LBS
12D600S	60,000 LBS	13" (330)	13" (330)	13" (330)	31/2" (90)	130 LBS

METRIC DIALS AVAILABLE AT NO EXTRA CHARGE.

DIMENSIONS: INCHES (MILLIMETERS)

TYPICAL SPECIFICATION FOR HYDRAULIC STATIONARY TANK SCALE

TANK SCALES SHALL BE OF THE HYDRAULIC LOAD CELL TYPE.

LOAD CELL SHALL BE OF THE TEMPERATURE STABLE, ROLLING DIAPHRAGM TYPE. LOAD PLATE SHALL BE ABLE TO TILT 4 DEGREES WITHOUT AFFECTING ACCURACY TO ALLOW EASY INSTALLATION. FLEXIBLE HOSE SHALL LEAD FROM THE LOAD CELL TO ALLOW EASY REMOTE INSTALLATION OF THE DIAL AND SHALL BE ___ FEET IN LENGTH. LOAD CELL SYSTEM SHALL REQUIRE NO ELECTRIC POWER AND SHALL BE IMMUNE TO ALL RFI/EMI, POWER FAILURES AND LIGHTNING STRIKES.

DIAL DIAMETER SHALL BE 12 INCHES AND READ ZERO TO ___ POUNDS WITH PROVISION FOR TARE ADJUSTMENT. DIAL SHALL BE CALIBRATED 2:1 TO LOAD CELL. TARE WEIGHT OF TANK WILL BE ___ POUNDS. DIAL ACCURACY SHALL BE BETTER THAN 1/2 OF 1%. TANK, HINGE AND HOLD DOWN HARDWARE TO BE FURNISHED BY OTHERS.

SCALE SHALL CARRY A MINIMUM FIVE (5) YEAR WARRANTY.

SCALE SHALL BE CHLOR-SCALE MODEL ___ AS MANUFACTURED BY FORCE FLOW EQUIPMENT, 1150-D BURNETT AVE., CONCORD, CA 94520.

OPTIONAL FEATURES

- 4-20MA TRANSMITTER (MODEL MA-420) - LOOP POWERED 4-20MA TRANSMITTER (REQUIRES 12-45 VOLTS DC POWER)
- LEVEL ALARM (MODEL RS-5)-ADJUSTABLE HIGH/LOW LEVEL ALARM WITH 25 AMP MANUAL RESET RELAY OR (MODEL PS-10) FIXED 10 AMP PRESSURE SWITCH
- CIRCULAR CHART RECORDER - CHOOSE 1 OR 7 DAY; ELECTRIC OR WIND-UP
- ADDITIONAL HYDRAULIC HOSE AND FITTINGS - INDICATORS CAN BE REMOTE MOUNTED UP TO 200' FROM SCALE LOCATION

