

## FOR CHLORINE, SO2 AND AMMONIA CYLINDERS

- + SAFELY MONITOR AMOUNT USED AND REMAINING CHEMICAL
- + PREVENT UNDER AND OVERFEED CONDITIONS
- + HYDRAULIC — NO POWER REQUIRED
- + NON-CORROSIVE PVC PLATFORM
- + OPTIONAL 4-20MA OUTPUTS AND LEVEL ALARMS



*HYDRAULIC SYSTEM  
REQUIRES NO POWER!  
IT IS VIRTUALLY  
MAINTENANCE FREE  
AND IS IMMUNE TO  
POWER FAILURE,  
LIGHTNING STRIKES  
AND RFI / EMI.*



*WALL MOUNTED CHAINING  
BRACKET INCORPORATES  
TOOL HOOKS TO STORE  
CYLINDER CHANGE-OUT  
TOOLS.*



THE CHLOR-SCALE 150 IS DESIGNED TO MONITOR 150 LB. CHLORINE, SULFUR DIOXIDE AND AMMONIA CYLINDERS COMMONLY USED AT WATER AND WASTEWATER TREATMENT PLANTS, WELL HEADS, BOOSTER STATIONS AND INDUSTRIAL PLANTS. A LOW OVERALL HEIGHT OF ONLY 15/8" ALLOWS CYLINDERS TO BE EASILY ROLLED ON AND OFF WITHOUT LIFTING AND A WALL MOUNTED CHAINING BRACKET PROVIDES THE SAFEST POSSIBLE INSTALLATION BY SECURING THE CYLINDER TO THE BUILDING STRUCTURE ITSELF.

A LARGE DIAL INDICATOR WITH CONVENIENT TARE ADJUST KNOB ALLOWS EASY OPERATION AND PROVIDES PLANT OPERATORS WITH CRITICAL INFORMATION AT A GLANCE. OPTIONAL REMOTE MOUNTED INDICATORS (UP TO 25') PROVIDE OPERATORS WITH AN ADDED LEVEL OF CONVENIENCE AND SAFETY BY PREVENTING UNNECESSARY ENTRY INTO THE CHLORINE BUILDING.

BECAUSE THE CHLOR-SCALE 150 HAS AN ALL PVC PLATFORM WITH CORROSION RESISTANT FASTENERS AND FITTINGS, YOU CAN FORGET ABOUT CORROSION NORMALLY ASSOCIATED WITH CHLORINE AND SWEATING CYLINDERS. IN ADDITION, OUR INCREDIBLY SIMPLE "PIVOTED PLATFORM" DESIGN HAS NO MOVING PARTS. THIS MEANS THAT THERE ARE NO FLEXURES, LEVERS OR MECHANICAL LINKS THAT ARE SUSCEPTIBLE TO CORROSION, BENDING OR BREAKING.

A FULL 5-YEAR WARRANTY BACKS EACH AND EVERY CHLOR-SCALE 150 INCLUDING THE PLATFORM, LOAD CELL AND DIAL INDICATOR. BUYING A CHLOR-SCALE 150 MEANS BUYING THE BEST!

# HYDRAULIC CHLOR-SCALE 150

## MODELS AND ORDERING INFORMATION

MODELS INCLUDE PLATFORM ASSEMBLY, LOAD CELL WITH 6 FEET OF TUBING, CHAINING BRACKET/TOOL RACK AND DIAL INDICATOR. FOR TUBING LENGTHS OVER 6 FEET, ADDITIONAL CHAINING BRACKETS, 4-20MA AND LOW-LEVEL ALARMS PLEASE CONSULT FACTORY. METRIC MODELS ARE AVAILABLE AT NO EXTRA CHARGE.

## CHLOR-SCALE 150 – FOR 150 LB. CHLORINE, SO<sub>2</sub> & AMMONIA CYLINDERS

MODEL NUMBER		DESCRIPTION	TECHNICAL DATA	
STANDARD	METRIC		<b>DISPLAY</b> • 4.5" CENTURY DIAL  <b>PLATFORM</b> • SOLID PVC WITH TUF-COAT FINISH  <b>INPUT</b> • HYDRAULIC LOAD CELL  <b>TARE ADJUSTMENT</b> • TARE ADJUST KNOB  <b>OUTPUTS</b> • OPTIONAL 4-20MA OUTPUT • OPTIONAL DRY CONTACT LEVEL ALARM  <b>REMOTE DIAL MOUNTING</b> • OPTIONAL QUICK CONNECTS WITH ADDITIONAL TUBING FOR ROUTING THROUGH CONDUIT OR WALL	
4D150-1	4D100K-1	SINGLE 150 LB CYLINDER SCALE FOR CHLORINE AND SO <sub>2</sub>		
4D150-2	4D100K-2	DUAL 150 LB CYLINDER SCALE FOR CHLORINE AND SO <sub>2</sub>		
4D400-1AS	4D200K-1AS	SINGLE 150 LB CYLINDER SCALE FOR AMMONIA		
SCALE DIMENSIONS		INCHES (MILLIMETERS)		
MODEL NO.	A	B	C	D
4D150-1, -2	13.5	18.625	16.5	1.625
4D100K-1, -2	(345)	(473)	(420)	(42)
4D400-1AS	15.75	21.5	18.75	1.625
4D200K-1AS	(400)	(546)	(476)	(42)

CHLOR-SCALE 150 ACCOMMODATES MOST INTERNATIONAL CYLINDER SIZES. EXAMPLE: 33KG, 68KG, 70KG, 100KG.

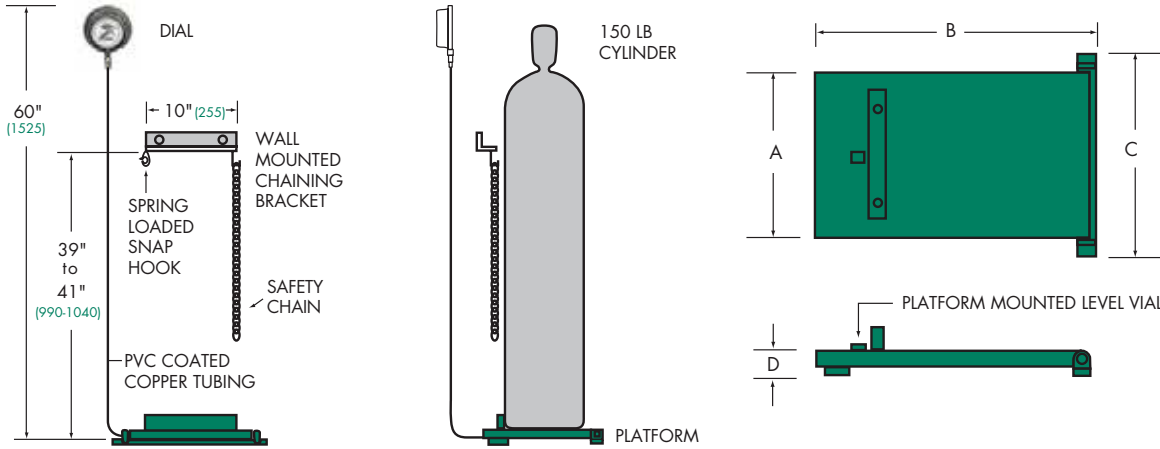

DIMENSIONS: INCHES (MILLIMETERS)



## TYPICAL SPECIFICATION FOR HYDRAULIC CHLORINE AND SO<sub>2</sub> 150 LB. CYLINDER SCALE

CYLINDER SCALE SHALL BE OF THE HYDRAULIC CELL TYPE. SCALE PLATFORM SHALL BE CONSTRUCTED OF NON-CORROSIVE 1 INCH PVC PLASTIC AND SIZED TO ACCEPT ONE (1) 150 LB (68KG) CYLINDER. A TOTAL OF \_\_\_\_\_ CHLORINE/SO<sub>2</sub>/AMMONIA CYLINDERS SHALL BE WEIGHED. PLATFORM HEIGHT SHALL BE NO MORE THAN 1-5/8" TO ALLOW EASY LOADING OF CYLINDER. PLATFORM SCALE COATING SYSTEM SHALL BE A MINIMUM DRY THICKNESS OF 80 MILS AND BE RESISTANT TO MOISTURE, CHEMICALS, ABRASION, IMPACT AND UV LIGHT.

LOAD CELL SHALL BE OF THE TEMPERATURE-STABLE, ROLLING DIAPHRAGM TYPE. FLEXIBLE PVC COATED COPPER TUBING SHALL CONNECT DIAL TO LOAD CELL FOR EASY PLACEMENT OF THE DIAL AND SHALL BE \_\_\_\_\_ FT. IN LENGTH (6 FT STANDARD). LOAD CELL SYSTEM SHALL REQUIRE NO ELECTRIC POWER AND SHALL BE IMMUNE TO ALL RFI/EMI, POWER FAILURES AND LIGHTNING STRIKES. CYLINDER CHAINING BRACKET SHALL BE WALL MOUNTED AND SHALL USE A DOUBLE COIL CHAIN AND A SPRING LOADED SNAP HOOK TO SECURE CYLINDER. CHAINING BRACKET SHALL HAVE AN INTEGRAL TOOL RACK FOR STORING CYLINDER CHANGE-OUT TOOLS.

DIAL DIAMETER SHALL BE AT LEAST 4.5" AND READ ZERO TO 200 LBS. (100KG) NET WITH PROVISION FOR TARE ADJUSTMENT. DIAL SHALL BE TEMPERATURE STABLE WITH DAMPER INSTALLED TO PREVENT SHOCK DAMAGE DURING CYLINDER LOADING.

SCALE SHALL CARRY FULL FIVE (5) YEAR FACTORY WARRANTY. "LIMITED" WARRANTIES SHALL BE CONSIDERED UNACCEPTABLE.

FULL SCALE ACCURACY SHALL BE BETTER THAN 1%. SCALE SHALL BE CHLOR-SCALE® 150 WITH TUF-COAT™ COATING AND CENTURY® DIAL INDICATOR, MODEL 4D\_\_\_\_AS MANUFACTURED BY FORCE FLOW, 2430 STANWELL DRIVE, CONCORD, CA 94520 USA (WWW.FORCEFLOW.COM).

## OPTIONS & ACCESSORIES

### SOLO XT®



SEE BULLETIN 514

### SOLO G2®



SEE BULLETINS 516 & 408

### WIZARD 4000®



SEE BULLETIN 407

- **4-20MA TRANSMITTER** (MODEL MA150)- LOOP POWERED 4-20MA TRANSMITTER FOR SCADA INTEGRATION (REQUIRES 12-45 VDC)
- **LOW LEVEL ALARM** (MODEL RS-150)- ADJUSTABLE LOW LEVEL ALARM WITH 10 AMP MANUAL RESET RELAY
- **CHAINING BRACKET** (MODEL CB-10)- ADDITIONAL CYLINDER RESTRAINT BRACKET

